

REVISIONS			
No.	DATE	BY	BRIEF DESCRIPTION

**FRAME AND GRATE DETAILS**

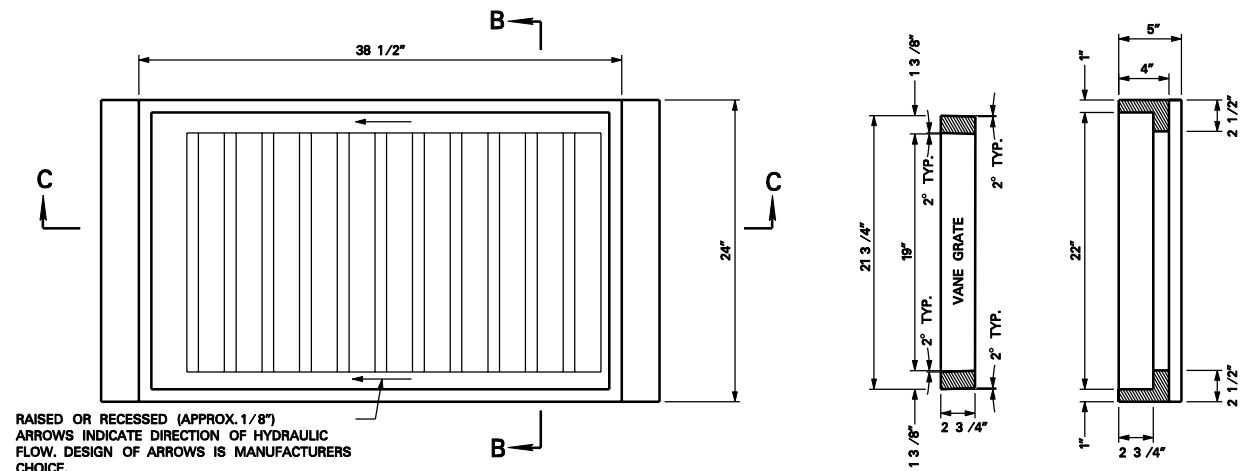

RAISED OR RECESSED (APPROX. 1/8")  
ARROWS INDICATE DIRECTION OF HYDRAULIC  
FLOW. DESIGN OF ARROWS IS MANUFACTURERS  
CHOICE.

**PLAN VIEW**

**SECTION B-B**

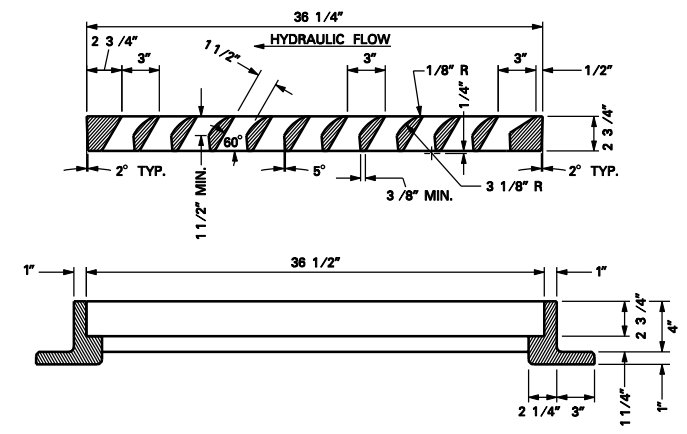

**SECTION C-C**

**CURB INLET DETAILS**

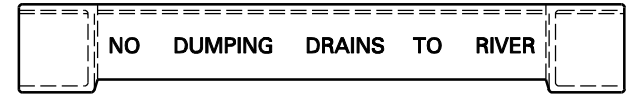

**PLAN VIEW**

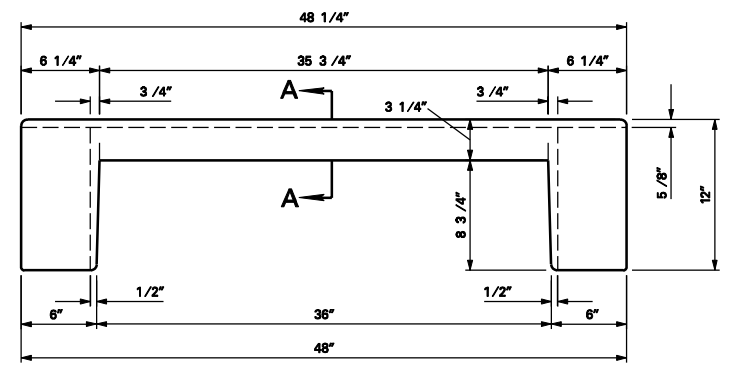

**FRONT**

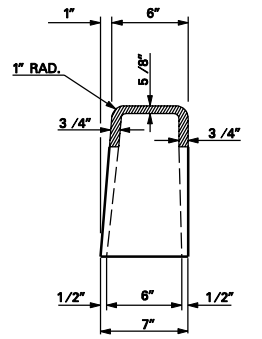

**SECTION A-A**

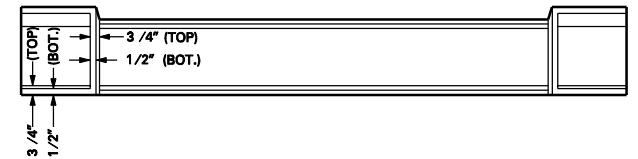

**BOTTOM**

**NOTES:**

1. RAISED LETTERING FOR CASTINGS SHALL HAVE A MINIMUM HEIGHT OF 1/2".
2. ALL CASTINGS SHALL CONFORM TO ASTM A48 CLASS 30.
3. ENVIRONMENTAL STATEMENT ON CURB INLET SHALL BE AS NOTED OR EQUIVALENT.
4. CASTINGS SHALL BE TREATED WITH TWO COATS OF BITUMINOUS PAINT.
5. FOR CLEARNESS, ALL CORNERS ARE SHOWN ON THIS DRAWING BY STRAIGHT LINES WITH THE EXCEPTION OF THE 1" RADIUS AT THE TOP OF FACE OF CURB. ALL INSIDE CORNERS SHOULD BE MADE WITH 1/2" X 1/2" FILLETS OR 3/4" RADIUS FILLETS FOR EASE IN MOULDING.

CITY OF KNOXVILLE DEPARTMENT OF ENGINEERING		DRAWN: RAW DATE: 18-NOV-01 CHECKED: NLT APPROVED: DTH
STANDARD DETAIL FOR TYPE 'B' CAST IRON FRAME, GRATE AND INLET FOR COK-9 AND FOR TDOT CATCH BASINS, Nos. 10, 12, 14, 16 AND 17		COK-10