

Targeted Constituents

● Significant Benefit ◐ Partial Benefit ○ Low or Unknown Benefit

● Sediment	○ Heavy Metals	○ Floatable Materials	○ Oxygen Demanding Substances
○ Nutrients	○ Toxic Materials	○ Oil & Grease	○ Bacteria & Viruses
			○ Construction Wastes

Description

A filter berm, made of natural materials that already occur on the project site, may be both efficient and cost-effective. Filter berms may be constructed of brush or rock materials, either with or without the use of a supplementary geotextile fabric. Both types of filter berms are placed along a level contour where overland sheet flow can be detained and ponded. If properly anchored, brush or rock filter berms may be used for sediment trapping and velocity reduction. This practice significantly reduces sediment.

Suitable Applications

- Below the toe of slopes.
- Along the site perimeter.
- Along streams and channels, or adjacent to roadways.
- Around temporary spoil areas or other small cleared areas.

Approach

A filter berm can often be constructed from natural materials, such as brush or rocks. This is generally an efficient operation for the site contractor if these materials are already present on the project site, both timewise and in terms of installation cost. Brush and rock filter berms can also be installed with a geotextile fabric to increase sediment removal filtration and the overall stability of the berm. Wire netting (such as poultry fencing) can also be used to increase the stability for brush or rock berms. Gabions and other wire mattresses can also be used as a rock filter for erosion control.

Both types of filter berms are placed along a level contour. Common applications are along the edge of a gravel roadway or 5 to 7 feet beyond the toe of a slope, where overland sheet flow can be detained and ponded. Brush or rock filter berms slow the velocity of overland runoff, allowing sediment to settle out or become trapped in the filter. In this manner, the brush and rock filter berms are very similar in function to ES-13, Check Dams, except that filter berms handle overland sheet flow and check dams handle stormwater runoff channels. A similar application involving sand or gravel is ES-16, Sandbag Barrier.

Brush and rock filter berms both contain materials (dirt, leaves, dust, silt) which could potentially cause more pollution than they might remove. These measures should be constructed and managed carefully in order to become effective BMPs. A silt fence or straw bale barrier may be needed as a secondary measure to control dirt and leaves.

Brush Filter Berms

A brush filter berm is composed of brush, small tree limbs, rootmat, grass and leaves, or other material which is commonly generated as waste during the clearing and grubbing stage. The brush filter berm is constructed by piling these materials into a continuous and compacted mound along a level contour which is downhill from a disturbed area. Large logs or tree stumps should generally be avoided as part of the brush filter berm; they cause large voids or gaps in the berm and so defeat the purpose of detaining stormwater. However, large logs by themselves can be used to slow stormwater runoff in wooded areas, along paths and trails, or at the bottom of slopes.

A brush filter berm height of approximately 3 feet is recommended to slow or detain stormwater. The minimum height of 2 feet may be used for short slopes less than 100 feet long. A corresponding width is generally 5 to 10 feet, with a shape that can either be triangular or somewhat rounded. Standard dozers or other grading equipment are used to compact and shape the brush filter berm to be more dense. Use rope or sturdy string to shape the brush filter berm and to hold it together.

A geotextile fabric can be used to increase the sediment retention or to provide a more stable brush filter berm. Install the filter fabric into a trench 6 inches deep immediately uphill from the formed berm. Then lay the filter fabric over the front face of the brush filter berm. Secure the filter fabric using staples, stakes, ropes or wires so that the fabric will not be uplifted by winds or storms. Overlap edges of filter fabric by 6 inches.

Brush filter berms are generally not used in developed areas or wherever aesthetics will be of concern. Brush filter berms may also be unpredictable in terms of performance. Since they are composed of natural materials, they may or may not need to be removed after the uphill sites are stabilized. Brush filter berms may provide a habitat for various types of desirable wildlife, or they could harbor pests and rodents in areas where these problems are known to exist.

Rock Filter Berms

A rock filter berm can be created from natural gravel or rock at the project site, or from imported gravel and rock. It is placed and compacted along a level contour, where sheet flow may be detained and ponded to promote sedimentation. Some type of geotextile fabric or wire screen is recommended to keep the berm shape intact. A gabion or wire mattress may be used to construct a rock filter berm, provided that the gabion wire spacing is compatible with size of aggregate or rock.

Rock filter berms can be used along the downslope edge of roadways or 5 to 7 feet beyond the toe of a slope. Rock filter berms can also be incorporated as part of a gravel road and other type of unpaved traffic area, in order to prevent stormwater from flowing into paved roads.

Construct a rock filter berm by first placing larger rocks as a base. If available, smaller rocks or gravel are placed on the uphill side of the larger rocks to form a natural filter. Geotextile filter fabric can be underneath the rock filter berm itself, which would adequately anchor the fabric. For areas where concentrated flows may occur, use larger rock without any dust or fine material, placed in a gabion or other type of staked woven-wire mattress.

Supplemental Materials

A geotextile filter fabric may be used to increase sediment retention. Burlap or other type of porous cloth material may be used in instances where no sediment is expected. At the toe of a graded slope or other instances with substantial amounts of sediment, a silt fence fabric should be selected. Consult ES-14, Silt Fence, for additional recommendations and trenching for geotextile fabric.

For areas with little potential for sediment, wire netting may be used to stabilize the filter berm. Woven-wire sheathing, such as frequently used for gardens and for poultry fencing, is typically 20-gauge galvanized wire, woven as a hexagonal mesh.

Stakes can be used to secure geotextile fabric or wire netting. Space wood, metal, or biodegradable stakes to prevent damage from wind uplift for geotextile fabric.

Maintenance

- Inspect filter berms after each rainfall event and also weekly for damaged fabric, excessive sediment buildup, undercutting flows or flows around end of filter berms. Repair or replace as necessary.
- Remove accumulated sediments when depth reaches 6 inches in front of filter berm. Dispose at onsite locations where sediment will not erode or become resuspended. Reshape filter berms and replace brush, rock, fabric, or stakes as needed.
- Remove filter berms after uphill drainage areas are stabilized. Natural materials such as brush and rock may be left in place if they do not cause any landscaping or nuisance problem. Remove all manmade materials (wire, stakes, fabric, etc).

Limitations

- Brush or rock filter berms shall not be used in live or continuously-flowing streams. Filter berms require sufficient space for ponded water.
- Installation and removal of filter berms may be difficult or time-consuming in areas with steep slopes or difficult access requirements. Consider how to remove rock filter berms during design phase.
- Not appropriate for contributing drainage areas greater than 2 acres. More reliable structural methods, such as temporary sediment traps and sediment basins, should be used if large amounts of sediment will be generated. Performance of brush filters may be relatively unpredictable.

References

30, 31, 32, 33, 34, 35, 141, 162, 167, 172, 179 (see BMP Manual Chapter 10 for list)

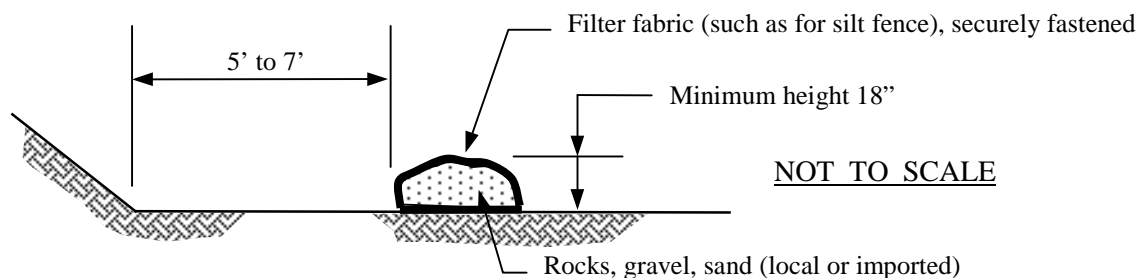

**Figure ES-17-1
Rock Filter Berm**

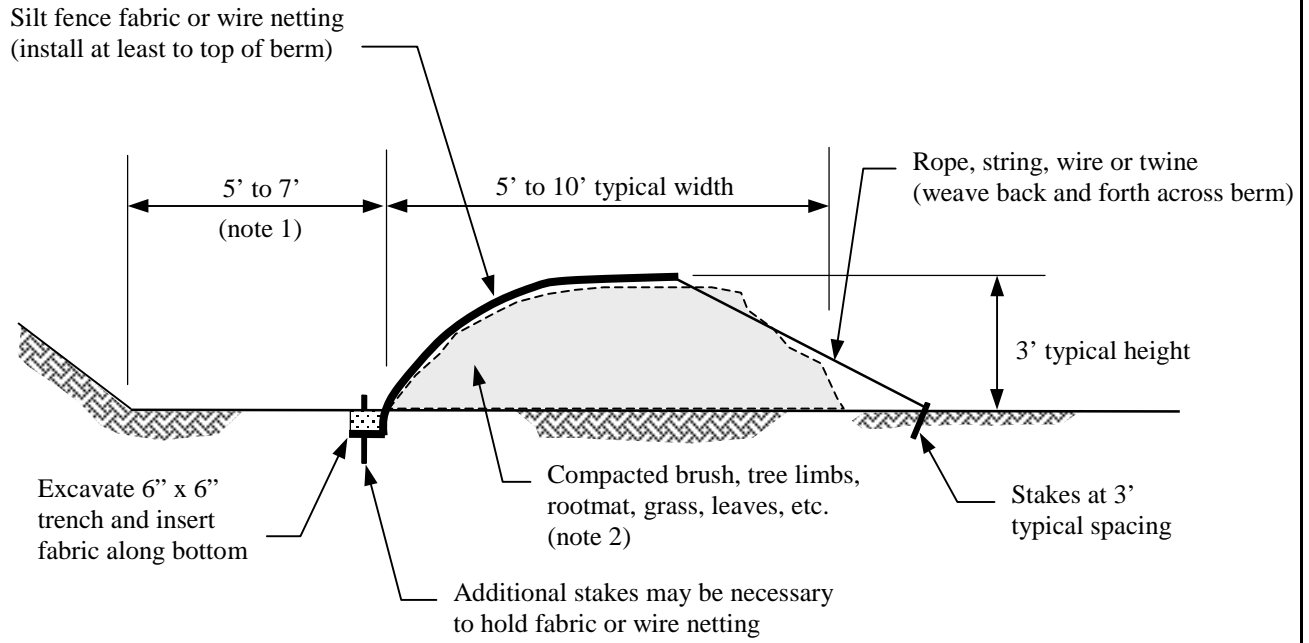

NOT TO SCALE

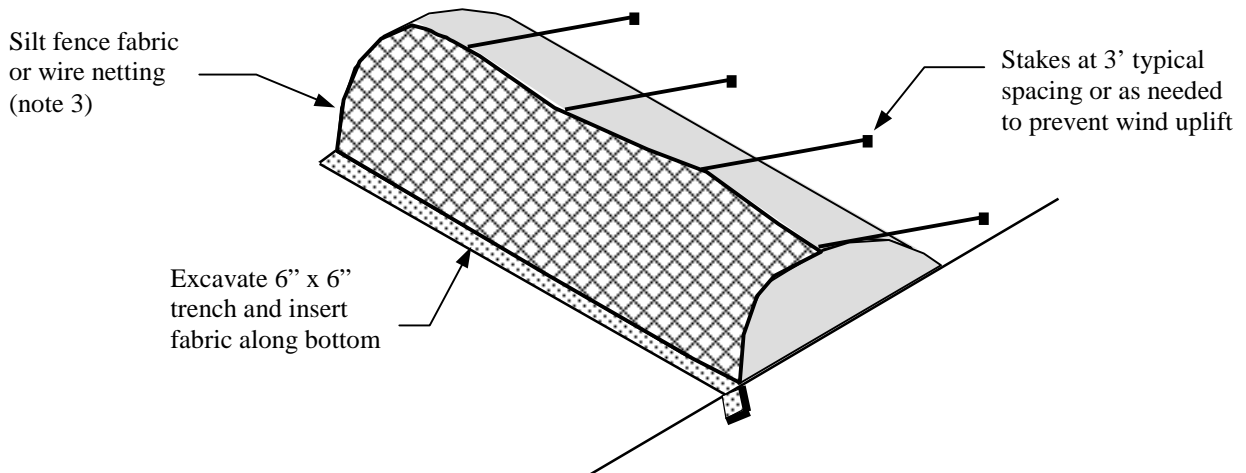

Notes:

1. Place brush filter berm at least 5 to 7 feet away from steep or long slopes to impound stormwater runoff. Wrap ends of brush filter uphill and anchor within slope.
2. Firmly crush and compact brush material so that it forms a dense berm. Prevent sticks and tree limbs from perforating silt fence fabric.
3. Silt fence fabric, if needed, is typically placed on the front half of brush filter berm. Wire netting is typically placed all the way across the brush filter berm.

**Figure ES-17-2
Brush Filter Berm**