

Targeted Constituents

<input checked="" type="radio"/> Significant Benefit		<input type="radio"/> Partial Benefit		<input type="radio"/> Low or Unknown Benefit	
<input checked="" type="radio"/> Sediment	<input type="radio"/> Heavy Metals	<input type="radio"/> Floatable Materials	<input type="radio"/> Oxygen Demanding Substances		
<input type="radio"/> Nutrients	<input type="radio"/> Toxic Materials	<input type="radio"/> Oil & Grease	<input type="radio"/> Bacteria & Viruses	<input type="radio"/> Construction Wastes	

Description

A silt fence is a temporary filter fabric which is attached to supporting posts and entrenched into the ground. The silt fence intercepts small amounts of sediment from disturbed areas during construction operations. It is a fairly versatile tool which is used close to the erosion source or as a perimeter control. This practice is likely to create a significant reduction in sediment.

Suitable Applications

- At the bottom of a cleared slope or disturbed field.
- At the perimeter of disturbed construction areas.
- Along streams and ditches, or to protect sensitive areas.
- Around temporary soil or gravel stockpiles.
- Within a swale or ditch that has gentle slopes and drainage area less than 1 acre.

Approach

Silt fence is a well-known and common method for trapping sediment at or near the potential source of erosion. It also reduces the potential for overland sheet flow to concentrate into rills and gullies. Silt fence can be installed below slopes, along paved areas, in narrow buffer zones, along streams and many other locations without requiring vehicle access. Silt fence can be installed by hand or by using a small piece of trenching equipment. It is very dependable when used properly.

Silt fence must be designed and installed correctly to trap sediment. Silt fence is only meant to handle small quantities of stormwater runoff such as sheet flow. Silt fence ponds water and then slowly releases it through the openings in the geotextile fabric. It is crucial that silt fences are sufficiently anchored and supported, and that they follow the contours. Improperly installed silt fence (not entrenched or not following contours) causes worse erosion by concentrating stormwater runoff.

Silt fence is more effective in removing sediment than straw bale barriers. Silt fence is also more durable than straw bale barriers, requires less maintenance, and is often more cost-effective for most types of construction projects involving cleared land. Silt fence shall not be used in live or continuously-flowing streams. Silt fence can generally not be used in ditches or swales which drain areas greater than 1 acre. Do not use silt fence in steep ditches or swales where the design flow is greater than 2 feet per second.

A variation of silt fence in common use and manufactured by a few companies is a triangular-shaped structure with silt fence fabric on both sides. The triangular shape comes from a plastic or metal wire frame that provides continuous support similar to the wire reinforcement fabric described below. It requires a combination of staples and anchors to install the triangular silt fence. The outer edges of the triangular silt fence should be buried in a trench for most applications and then adequately stapled or staked. If necessary, a triangular silt fence can be installed with minimal or no trenching for short overland flows on gentle slopes. See Figure ES-14-2 for typical details.

A common variant of a reinforced silt fence (described below using wire reinforcement backing) is to use a staked straw bale barrier as the reinforcement backing for the silt fence. A combined trench can be excavated as the first step, and then both erosion control structures are installed in the normal manner, with the silt fence being upslope.

Materials

- Synthetic filter fabric is typically manufactured from woven or nonwoven sheets of polypropylene, nylon or polyester. Silt fence fabric must contain stabilizers to slow degradation from ultraviolet light. Silt fence fabric should resist rotting, mildew, insects and rodents.
- Burlap fabric is not appropriate for use as silt fence, except possibly temporary applications of less than 45 days at minor locations. Burlap fabric should be inspected more often and must be replaced every 60 days.
- Silt fence fabric comes in rolls with a typical width of 36 inches. For most applications, 12 inches will be embedded into the ground and 24 inches will be aboveground to trap sediment. Silt fence can be installed on either wood or steel posts of adequate strength.
- Typical values for silt fence fabric are listed in the table below. Some vendors offer a standard strength fabric and also an extra strength fabric for critical applications. For the flow rate of 0.30 gallons per minute per square foot, the silt fence fabric release rate is 0.07 cubic feet per second for every 100 feet of silt fence with ponded height of 1 foot.

Typical Properties for Silt Fence Fabric	
Property	Typical Values (MARV)
Tensile strength at 20% elongation:	
Standard strength fabric	50 pounds per linear inch
Extra strength fabric	100 pounds per linear inch
Burst strength	180 psi
Trapezoidal tear strength	50 pounds
Apparent opening size	20 to 30 (US sieve size)
Flow rate	0.30 gallons per minute per square foot

- Wood posts are typically 2” x 2” oak and other hard woods. A larger size post is necessary for pine and other soft woods, such as 4” x 4”. Typical post length is 48 inches, with minimum height of 24 inches above ground and minimum depth of 18 inches below ground. See Figure ES-14-1 for typical post and trenching details.
- Fasteners for wood posts are typically either wire staples or nails. There shall be a

minimum of 5 fasteners for each wood post. Use minimum size 17-gauge staples with a minimum embedded length of 1 inch into the wood and a minimum width of 3/4 inch across. Typical nail size is 1 inch long with an oversized nail head (such as 3/4-inch diameter head) to prevent fabric from ripping. Additional nails may be necessary if a small nail head is used.

- Steel posts are typically either a C-shape, L-shape, T-shape or U-shape with a minimum weight of 1.33 pounds per linear foot, with sufficient holes and hooks for fasteners. Typical fasteners for steel posts are either installed hog rings, attached loops of cord or string, or sewn pockets within the fabric.
- Steel wire reinforcement fabric may be necessary for installations within stormwater channels or on steep slopes. Steel wire reinforcement shall be minimum 14-gauge with a maximum mesh spacing of 6 inches. Typical methods of attaching steel wire reinforcement are tie wires or hog rings.
- The drainage area for a typical silt fence installation at the bottom of a slope shall not exceed 10,000 square feet for every 100 feet of silt fence. For a rectangular area, this means a maximum average slope length of 100 feet which is only permissible for slopes flatter than 2 percent.

Installation Guidelines

Maximum Slope Lengths for Silt Fence Installations	
Land Slope	Maximum Slope Length
Less than 2 %	100 feet
From 2 to 5 %	75 feet
From 5 to 10 %	50 feet
From 10 to 20 %	25 feet
More than 20 %	15 feet

- Do not staple silt fence fabric to existing trees, as this does not allow adequate trenching and backfill near the tree trunk. Other erosion control methods may also be appropriate in areas where existing trees and vegetation are to be protected, or where excavating a trench is not feasible.
- Silt fence fabric should be purchased in continuous rolls of acceptable width in order to avoid creating a joint (which would be the potential location of a blowout). When joints are unavoidable, install 2 support posts in close proximity to each other and then overlap the two silt fence fabrics by 1 post in each direction.
- Locate silt fence at least 5 to 7 feet beyond the base of steep slopes. In locations at the bottom of a slope, turn the ends of the silt fence upslope so that a certain depth of stormwater may be retained in front of the silt fence. The impounded depth should be at least 12 inches but less than the silt fence height. Install straw bale barriers at the end of the silt fence row as an “emergency overflow” to allow detained water to be filtered quickly. See Figure ES-14-3 for a typical layout using straw bales at the end of silt fence.
- If a silt fence is installed in a stormwater ditch or swale, then steel wire reinforcement is highly recommended. Maximum post spacing shall be 4 feet or less. The silt fence should have the ends oriented upstream to resemble a horseshoe pattern, as shown in Figure ES-14-4.

Common problems with silt fence are:

- Not adequately entrenched into the ground.
- Installed too low, particularly at sag point between posts or as fabric stretches.
- Not installed on a level contour.

Installation Procedure

Step 1: Prepare the grade and alignment for the silt fence installation. Clear brush and reshape ground profile as necessary. Ensure that silt fence is installed along a level contour and that maximum slope lengths are not exceeded.

Step 2: Install wood or steel posts at proper spacing to a minimum depth of 18 inches. Maximum length for most installations is 8 feet between posts. Shorten maximum spacing to 6 feet when installing silt fence below steep slopes or 4 feet within a ditch or channel that drains less than 1 acre.

Step 3: Excavate a trench 6 inches deep and 6 inches wide slightly uphill from the posts. Keep excavated soil nearby for use in filling the trench. A minimum depth of 4 inches may be used for locations with shallow bedrock or other difficult conditions.

Step 4: If necessary, attach wire fence reinforcement to posts at locations where washout or heavy flows may occur. Install wire fence reinforcement at least 3 inches into the trench and attach to posts. Wire fence reinforcement should extend a few posts to draw adequate strength from the embedded posts.

Step 5: Install filter fabric into the trench and attach to the posts using recommended materials. Embed into trench as shown in Figure ES-14-1. The minimum height of silt fence shall be 18 inches above the ground surface. Attach filter fabric to the top edge of wire fence reinforcement (if needed) at regular intervals to prevent sagging.

Step 6: Backfill the trench using the excavated soil and firmly compact. Carefully inspect silt fence installation to see if additional supports or posts are needed.

Maintenance

- Inspect silt fence after each rainfall event and also weekly for damaged or loosened fabric, excessive sediment buildup, undercutting flows or flows around end of silt fence. Repair or replace damaged silt fence as necessary.
- Remove accumulated sediment whenever it reaches one-third of the silt fence height. Shovel by hand to prevent damage to the filter fabric and posts. Dispose of accumulated sediment onsite to prevent movement of sediment.
- The expected life of silt fence fabric is usually 6 to 8 months. Inspect silt fence often as the fabric weathers and deteriorates. Install new silt fence as needed to ensure proper erosion control.

Limitations

- Silt fence shall not be used in live or continuously-flowing streams. Silt fence can generally not be used in channels which drain areas larger than 1 acre.
- Installation and removal may damage vegetation and channel grades. Do not place in grass-lined channels unless erosion and sediment are expected. Silt fence may kill vegetation by excessive sediment or by long periods of submergence.

References

8, 30, 31, 32, 33, 34, 35, 41, 114, 136, 141, 144, 162, 172, 179
(see BMP Manual Chapter 10 for list)

Notes:

1. Post spacing shall 8 feet maximum for typical applications at the bottom of slopes or along site perimeter.
2. Post spacing shall be 6 feet maximum at the bottom of steep slopes. Post spacing shall be 4 feet maximum within a drainage channel.
3. Place silt fence at least 5 to 7 feet away from steep or long slopes to impound stormwater runoff. See Figure ES-14-3.
4. Wire fence reinforcement is required below slopes that are over 8' high, or where silt fence is installed immediately adjacent to grading limits. Install reinforcement at locations where washout or heavy flow may occur.

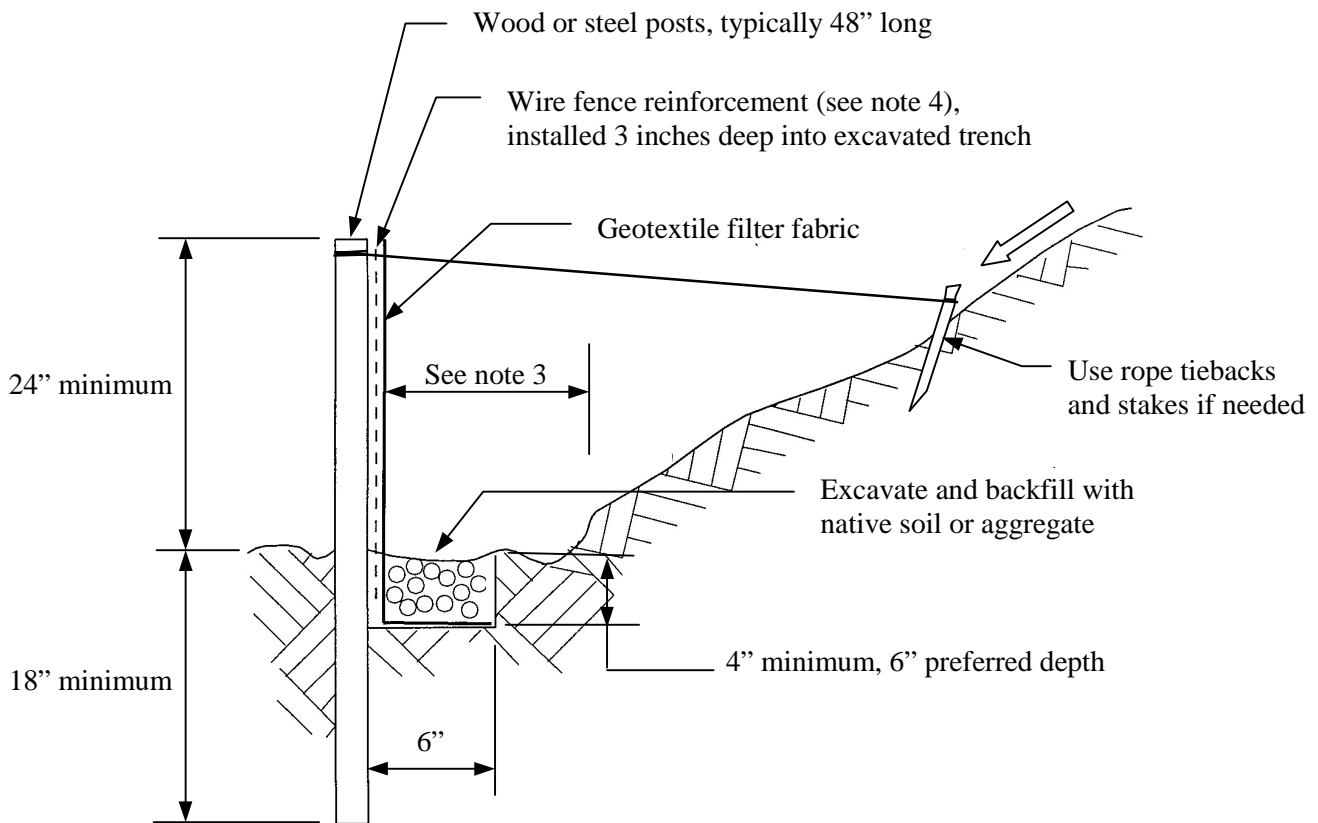
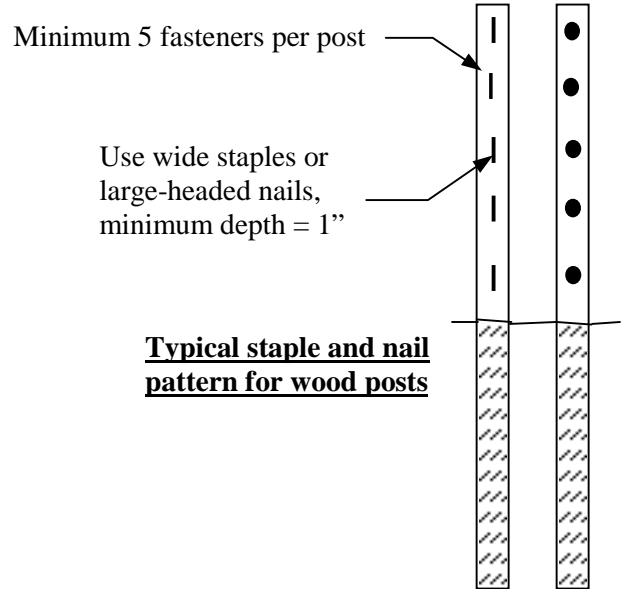

NOT TO SCALE

**Figure ES-14-1
Typical Silt Fence Installation**

Notes:

1. Two alternative installations are shown for a trenched geotextile fabric and for a geotextile fabric apron. Follow recommendations of manufacturer regarding staples and stakes. Stakes should typically be driven 18" into ground.
2. Typical height is 18" to 24".

Features of triangular silt fence include:

- Available as prefabricated units from several manufacturers in stackable form
- Triangular shape allows static water pressure to press the structure downward.
- The support frame is reusable.
- Can be adapted to many different uses.
- Trenching may not be necessary for minor overland flow applications if a geotextile fabric apron adheres closely to a prepared ground surface.

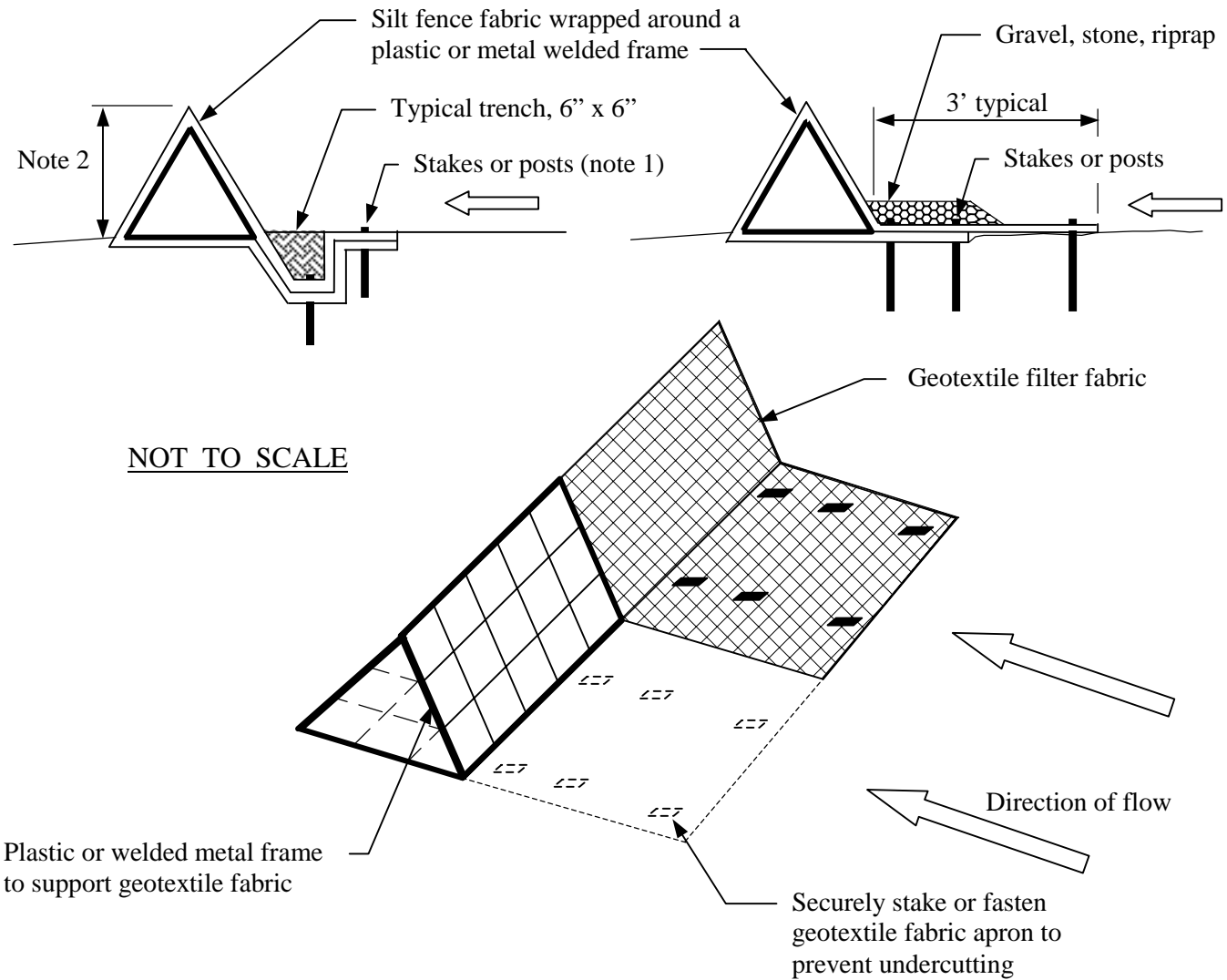

Figure ES-14-2
Triangular Silt Fence

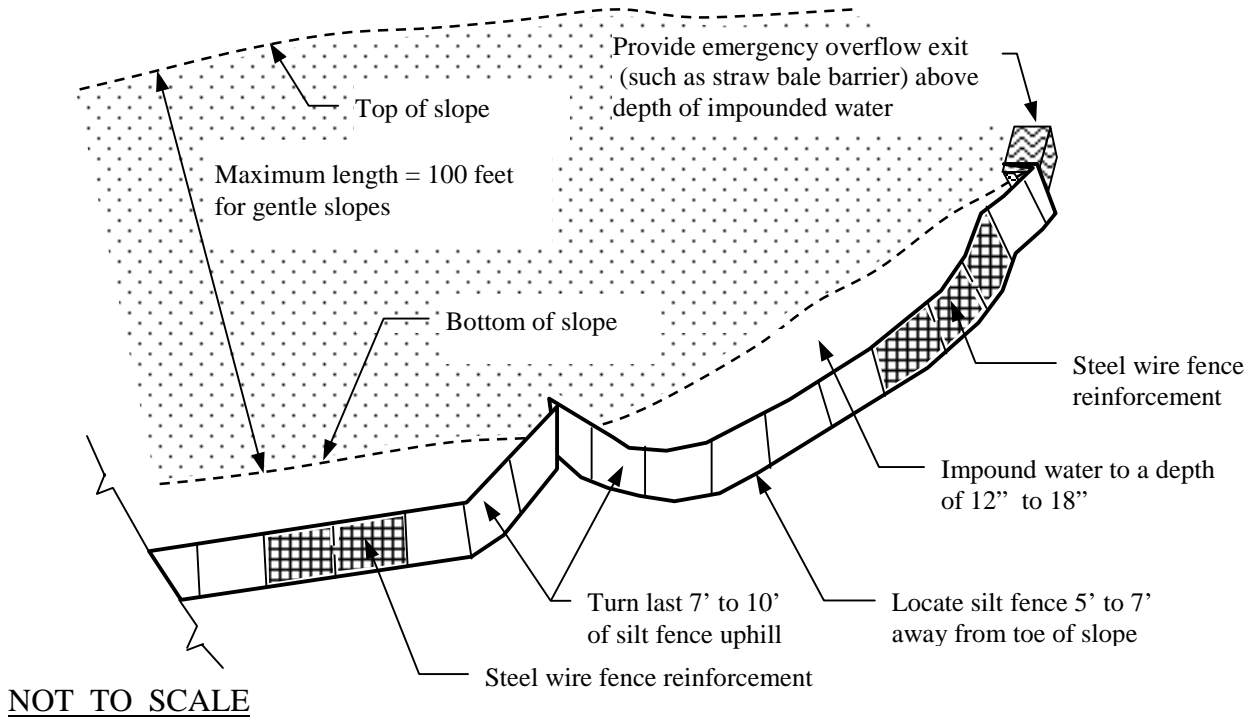

Figure ES-14-3
Silt Fence (Below a steep or long slope)

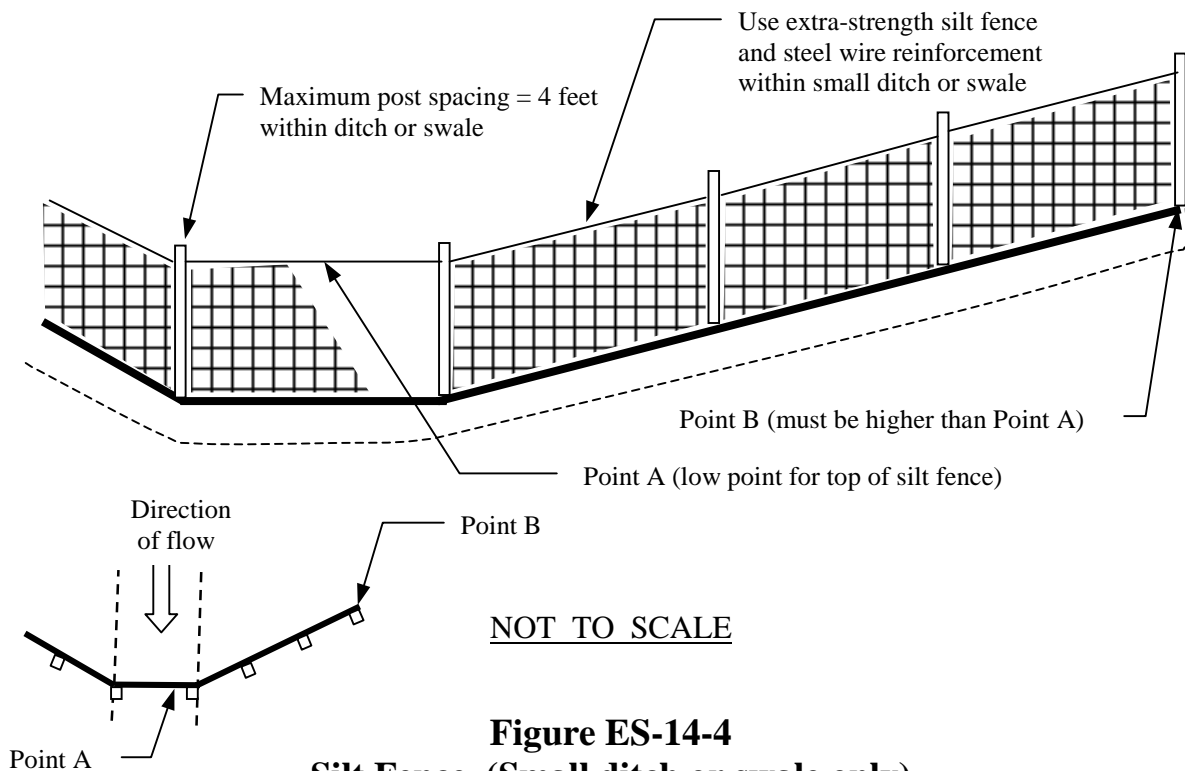

Figure ES-14-4
Silt Fence (Small ditch or swale only)