

Targeted Constituents

● Significant Benefit ▸ Partial Benefit ○ Low or Unknown Benefit

● Sediment	▸ Heavy Metals	○ Floatable Materials	○ Oxygen Demanding Substances
○ Nutrients	▸ Toxic Materials	▸ Oil & Grease	○ Bacteria & Viruses
		○ Bacteria & Viruses	○ Construction Wastes

Description

Prevent or reduce the discharge of pollutants to stormwater systems and natural streams from dewatering operations by using sediment controls and by testing the groundwater for pollutant accumulation. This management practice is likely to create a significant reduction in sediment and may contribute to a partial reduction in toxic materials, heavy metals or petroleum products.

Approach

There are two general classes of pollutants that may result from dewatering operations: 1) sediment; and 2) toxic materials, petroleum products, or other dissolved pollutants. This BMP will only address sediment removal from dewatering operations.

Large amounts of sediment in dewatering discharges are common due to the nature of the operation. On the other hand, toxic materials and petroleum products are not commonly found in dewatering discharges unless the site or surrounding area has been used for industrial activities. A site assessment prior to construction or development will reveal whether the area has a history of groundwater contamination.

This BMP only addresses the capture of sediments through the use of filtering devices. If it is determined that dewatering will result in transfer or accumulation of toxic materials or petroleum products, then the Tennessee Department of Environment and Conservation (TDEC) must be consulted before any dewatering activities take place.

Use sediment controls to remove sediment from water generated by dewatering. This may include techniques presented in the attached figures, the use of sediment traps or sediment basins, or other filtering methods. Monitor discharge water continuously. Suspend operations immediately if sediment or other pollutants is being discharged.

Types of sediment filtration methods include:

- Portable sediment tank
- Filter box
- Straw bale / silt fence pit
- Commercially available geotextile filter products
- Filtration through aggregate and silt fence cloth

The minimum volume formula for sizing the filtration devices (except for the commercially available devices) is:

$$V = 16 Q \quad \text{where} \quad \begin{array}{l} V = \text{volume of required storage (cubic feet)} \\ Q = \text{pump discharge (gallons per minute)} \end{array}$$

Locate sediment filtration devices in locations to minimize interference with construction activities. Position filtration devices for easy cleanout and disposal of trapped sediment. A stable access path should be provided for vehicles to access the larger structural filtration devices, such as the portable sediment tank or the filter box.

Filter Box

- A typical filter box is shown in Figure AM-12-1. The box should be made of steel, sturdy wood or other materials suitable to handle the pressure requirements imposed by the water and sediment. A common application is 55-gallon drums welded top to bottom.
- Make bottom of the filter box porous by drilling holes. Place aggregate base in the bottom of the filter box to a minimum depth of 12 inches. Metal screens may be needed beneath the aggregate to retain the stone.
- Direct effluent over a well-vegetated strip with a flow path of at least 50 feet. The effluent discharge point may be relocated to discharge to other well-vegetated strips as needed.
- When water level nears the top of filter box, shut off pump while the filter box drains. Design filter box to allow for emergency flow through top of filter box.
- If the aggregate filter becomes clogged with sediment, the stones must be cleared from the inlet, cleaned, and then replaced. Clean out tank when one-third of the original capacity is depleted due to sediment accumulations. Clearly mark tank to show the cleanout point.

Portable Sediment Tank

- A typical portable sediment tank is shown in Figure AM-12-2. Construct with steel drums, sturdy wood or other material suitable for handling the pressure exerted by the water and sediment. The tank should be sturdy enough to enable transfer offsite under fully-loaded conditions.
- Design a system of baffles, using openings at the top or bottom sections of joined steel drums, so that sediment is captured from pumped water prior to reaching the last drum.
- Direct effluent over a well-vegetated strip with a flow path of at least 50 feet. The effluent discharge point may be relocated to discharge to other well-vegetated strips as needed.
- When water level nears the top of tank, shut off pump while the tank drains. Design tank to allow for emergency flow through top of tank.

- Sediment tank minimum depth is 24 inches. Clean out tank when one-third of the original capacity is depleted due to sediment accumulations. Clearly mark tank to show the cleanout point.

Straw Bale / Silt Fence Pit

- A typical straw bale / silt fence pit is shown in Figure AM-12-3. The excavated area should be a minimum of 3 feet below the base of the straw bales. Installation guidelines for straw bales should be in accordance with ES-15, Straw Bale Barrier. Silt fence fabric should be in accordance with ES-14, Silt Fence, and installed to cover the entire inside face of the straw bale dikes. Securely fasten silt fence above and below the straw bale barrier.
- The storage volume consists of two parts: the temporary filter volume and the wet storage pit. The temporary filter volume is essentially the working volume of the filtration device. The wet storage pit is intended for sediment storage and may be dewatered by pumping through a geotextile filter after a minimum of 6 hours time for sediment to settle.
- Direct effluent over a well-vegetated strip with a flow path of at least 50 feet. The effluent discharge point may be relocated to discharge to other well-vegetated strips as needed.
- When water level nears the crest of the stone weir (emergency overflow), shut off pump while the structure drains down to the top of wet storage pit. When the wet storage pit becomes filled to one-half of the excavated depth, accumulated sediment shall be removed and properly disposed.

Commercially Available Geotextile Filter Products

- There are many commercial products that are designed as filters for dewatering operations. Most products utilize geotextile material or fabric in the form of various-sized bags, tubes and packs.
- Design the filter bag, tube or pack according to the dewatering discharge requirements and manufacturer's recommendations. If it is determined that the filter bag, tube or pack is ineffective, then another type of filtration device may be required.
- Direct effluent over a well-vegetated strip with a flow path of at least 50 feet after leaving the filter. The effluent discharge point may be relocated to discharge to other well-vegetated strips as needed.
- The filters must be capable of being removed from the site without tearing or other accidental loss of material. Alternatively, the filter can be placed in a slotted grate or other containment that allows for additional drainage and easier site removal. If it is determined that the sediment does not contain pollutants, then the captured material may be used for grading and fill elsewhere on the site.

Other Sediment Filtration Designs

If there is sufficient space and volume, a dewatering impoundment may be constructed with structurally sound berms and control structures. A common method of filtration can be achieved using a perforated or slit standpipe with holes wrapped in filter fabric. The standpipe is surrounded by rock or aggregate which filters the water as it collects in the standpipe before being pumped out or discharged.

If the standpipe is being pumped out, then wrapping the standpipe in filter fabric may require an increased suction inlet area to avoid clogging and unacceptable pump operation. Alternatively, a floating suction hose in the impoundment will allow clean surface water to be pumped out after allowing time for settlement, typically overnight.

Direct discharged effluent over a well-vegetated strip with a flow path of at least 50 feet after leaving the filter. The effluent discharge point may be relocated from time to time to other well-vegetated strips as needed.

Toxic Materials and Petroleum Products

- In areas suspected of having groundwater pollution, sample the groundwater near the excavation site and have the water tested for known or suspected pollutants at a certified laboratory. Check with the TDEC for requirements for dewatering and water quality tests.
- It may be possible to treat pumped groundwater and discharge it to the municipal wastewater treatment plant via the sanitary sewer with written permission from Knoxville Utilities Board (KUB). KUB must be consulted prior to considering sanitary sewer as a disposal option.

Maintenance

- Inspect filtering device frequently. Repair or replace filtering device when sediment buildup prevents the structure from functioning as designed.
- Accumulated sediment removed from a dewatering device may generally be spread at the project site. Sediment that appears to be contaminated shall be stabilized and then disposed as hazardous waste at a licensed disposal site.
- Inspect excavated areas daily for signs of contaminated water as evidenced by discoloration, oily sheen, or odors. Notify TDEC and the City of Knoxville Engineering Department concerning the evidence of contaminated water. Promptly sample and test groundwater to determine nature and extent of pollutants.

Limitations

- The controls discussed in this BMP address sediment only. If the presence of polluted water is identified in the contract, the contractor shall implement dewatering pollution controls as required by the contract documents. If the quality of water to be removed by dewatering is later determined by observation or testing to be polluted, the contractor shall notify the appropriate authorities.

References

30, 31, 33, 34, 35, 100, 137, 141 (see BMP Manual Chapter 10 for list)

NOTES:

- 1. Weld shall be designed for the capacity of the tank.
- 2. For bottom drum, remove top cover only. Remove top & bottom covers for top & middle drums.

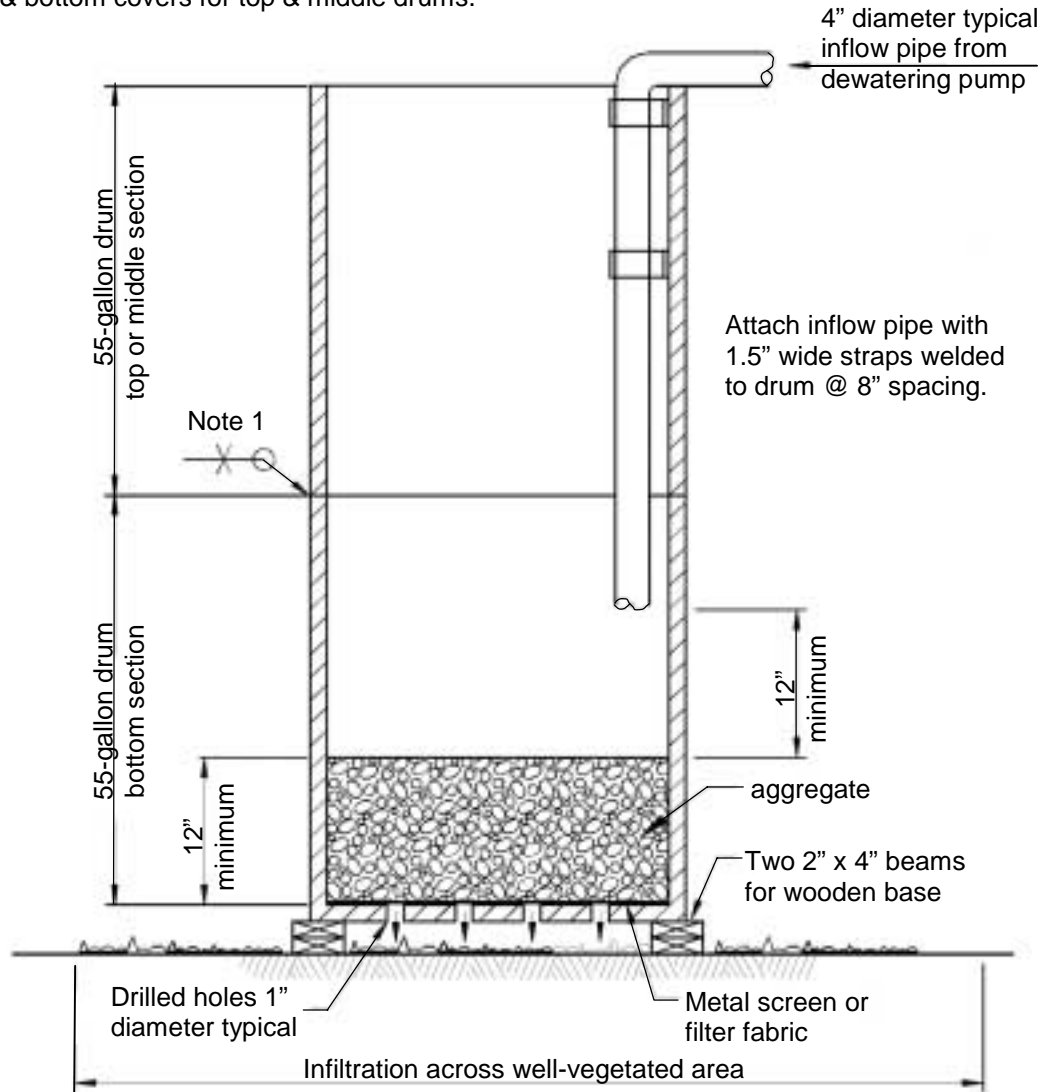

NOT TO SCALE

**Figure AM-12-1
Typical Filter Box**

NOTES:

1. Weld shall be structurally designed for the capacity of the tank and for transportation. Critical stress may occur during offloading and/or transportation.

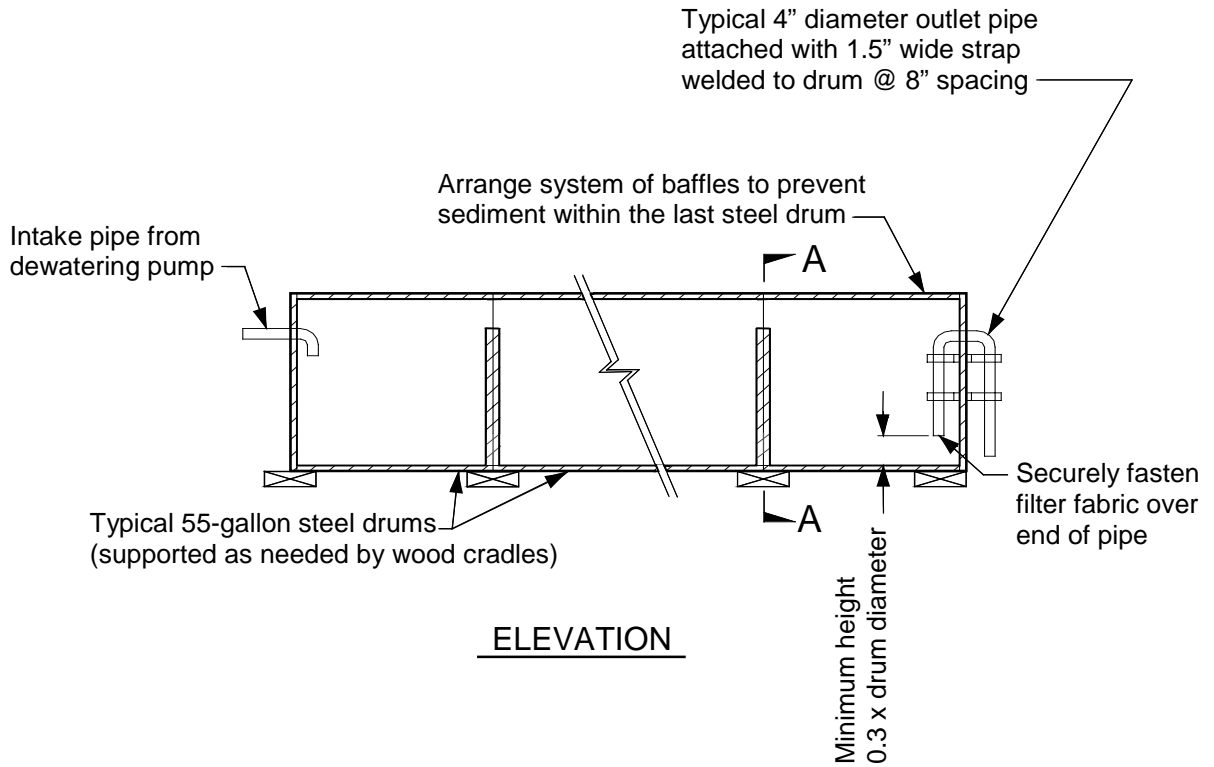
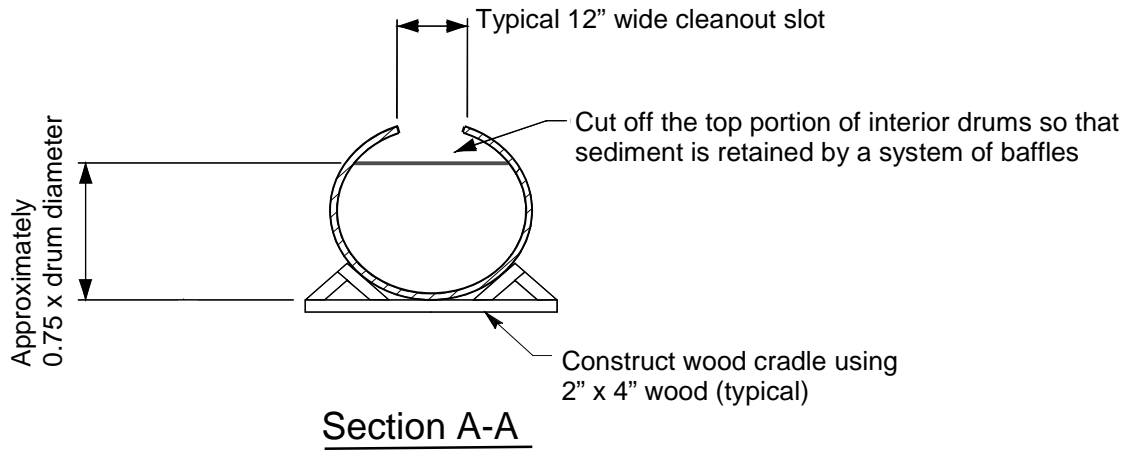

NOT TO SCALE

**Figure AM-12-2
Typical Portable Sediment Tank**

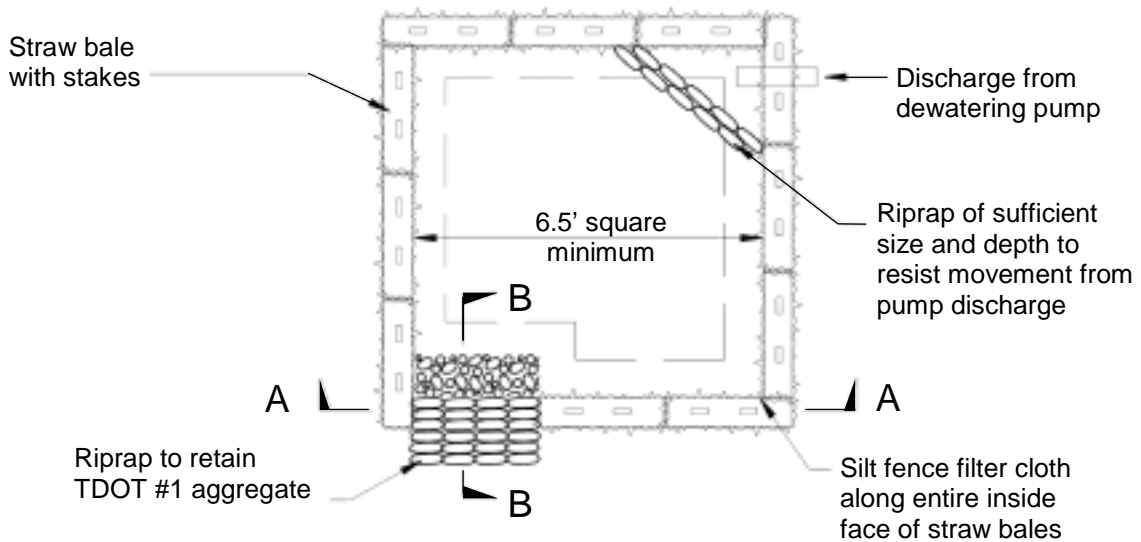
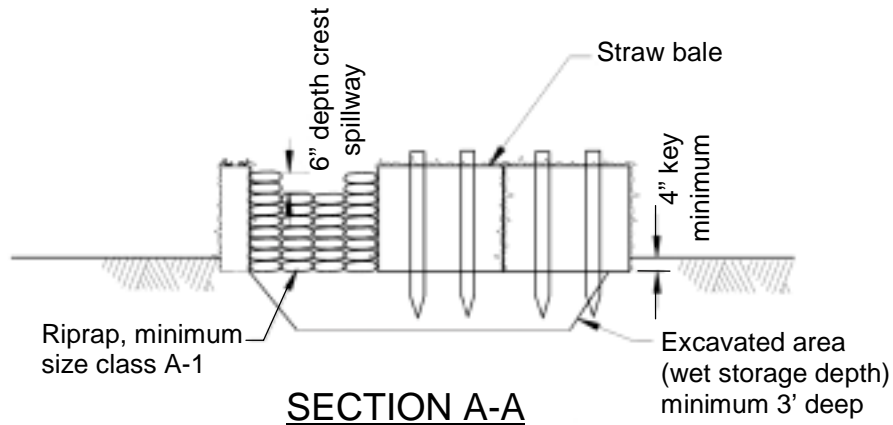
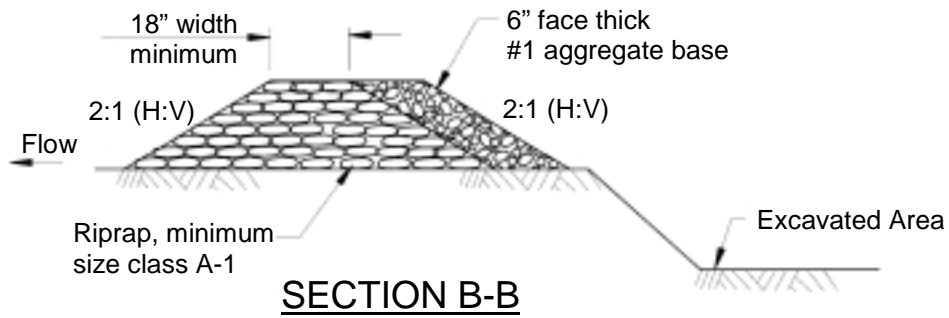

Figure AM-12-3
Typical Straw Bale / Silt Fence Pit